

PLD-40 SERIES: 915-975 nm, 30 W

Multi-mode Fiber-coupled Diode Lasers

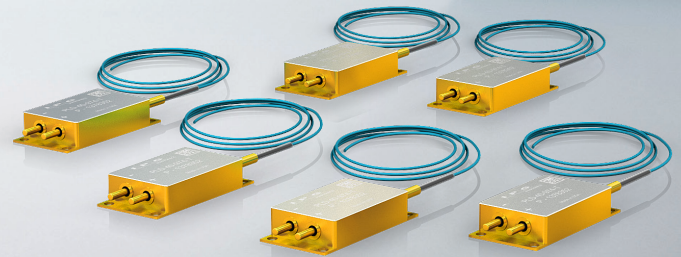
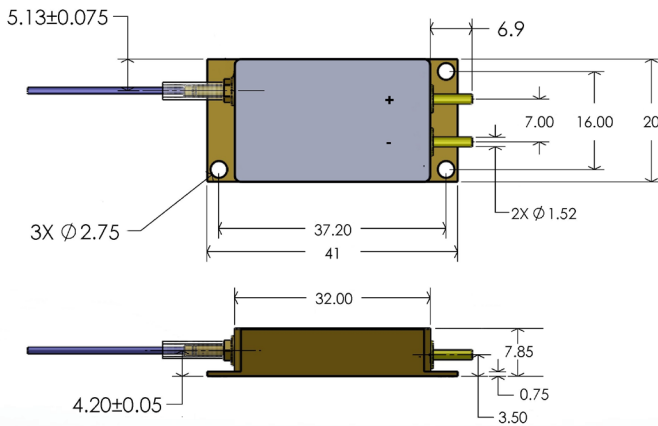

FEATURES

- ▶ Amplifier Pumping
- ▶ Laser Pumping
- ▶ Graphic Arts / Printing
- ▶ Illumination
- ▶ Direct Diode Lasers
- ▶ Material Processing
- ▶ Medical & Dental
- ▶ Photovoltaics



APPLICATIONS

- ▶ 915, 940, 975 nm Center Wavelengths
- ▶ 30 W Output Power
- ▶ Wavelength Stabilization Option at 975 nm
- ▶ 0.12 NA into 105 or 110 μm Fiber Core Diameter
- ▶ High Reliability
- ▶ Robust Compact Package

IPG Photonics' **PLD-40 Series** fiber-coupled diode lasers provide up to 30 W of output power within 0.13 NA. PLD-40 diode options include 105 μm or 110 μm fiber core diameter, and center wavelength at 915 nm, 940 nm or 975 nm. A wavelength stabilization option is also available at 975 nm.

IPG's best-in-class diode technology offers an ideal combination of power, reliability and form factor. We manufacture to rigorous telecom-grade standards in the world's largest high power diode fab. Each wafer is individually qualified, which sets IPG apart from alternative industrial pump products using short-lived diode bars and bar-stack technologies. PLD-40 diode lasers are preferred for fiber amplifier and laser pumping, material processing, and direct diode applications.

PLD-40 SERIES: 915-975 nm, 30 W

Multi-mode Fiber-coupled Diode Lasers

Optical and Electrical Characteristics*	PLD-40	PLD-975-40-WS
Center Wavelength, nm	915, 940, 975	975
Center Wavelength Tolerance, nm	± 3	± 0.5
Output Power, W	30	28
Spectral Width (FWHM), nm		5
Slope Efficiency, W/A	2.4	2.3
Conversion Efficiency, %	47	43.5
Threshold Current (I _{TH}), A		0.7
Operating Current (I _{OP}), A		12
Forward Voltage, V		4.8
Recommended Case Temperature, °C		25
Wavelength Shift with Temperature, nm/°C	0.35	< 0.01
Wavelength Shift with Operating Current, nm/A	1.2	< 0.1

*Typical performance data measured at 12A, 25°C.

Fiber Characteristics

Fiber Core Diameter, μm	105 or 110 options available
Fiber Cladding Diameter, μm	125
Fiber Buffer Diameter, μm	250
Beam Numerical Aperture (90% power)	0.13
Fiber Length, m	0.75 - 1.2
Minimum Fiber Bend Radius, mm	30

Maximum Ratings

Operating Current (I _{OP}), A	12
Reverse Voltage, V	2.5
Case Temperature, °C	5 - 70
Storage Temperature, °C	-30 to 80
Lead Soldering Temperature (10 s max) °C	300
Relative Humidity, %	85



+1 (508) 373-1100;

[IPGPhotonics.com/contact](https://www.ipgphotonics.com/contact)

www.ipgphotonics.com

MAX. AVERAGE OUTPUT POWER: 160 W
WAVELENGTH RANGE: 800-1000 nm

DANGER - INVISIBLE LASER
RADIATION AVOID EYE OR SKIN
EXPOSURE TO DIRECT OR
SCATTERED RADIATION
CLASS 4 LASER PRODUCT

IEC 60825-1:2014

Legal notices: All product information is believed to be accurate and is subject to change without notice. Information contained herein shall legally bind IPG only if it is specifically incorporated into the terms and conditions of a sales agreement. Some specific combinations of options may not be available. The user assumes all risks and liability whatsoever in connection with use of a product or its application. IPG, IPG Photonics, The Power to Transform and IPG Photonics' logo are trademarks of IPG Photonics Corporation. © 2023 IPG Photonics Corporation. All rights reserved.